

Multisensor True Presence DALI-2 Input Device — concealed

Multisensor

neva
lux

Multisensor True Presence DALI-2 Input Device — concealed

EAN: 4007841 081829

E-No: 535900069



Presence detector and air quality sensor in award-winning design with patented True Presence technology. Digitally adjustable detection and setting via the latest Bluetooth Mesh standard. DALI-2 input device (230 V power supply) transmits the collected sensor data to higher-level building management systems. Data collection on temperature, humidity, air pressure, CO2 and volatile organic compounds (VOC). Now with additional measurement of the noise level. Easy-to-install plug-in system with magnetic connection, integrated RGB LED traffic light and signal tone for visualising the room climate.

- UV-resistant plastic
- Interconnectable and adjustable via Bluetooth
- Digital high frequency sensor
- Visual and auditory signal on room climate

Multisensor True Presence DALI-2 Input Device — concealed

Multisensor



neva
lux

Multisensor True Presence DALI-2 Input Device — concealed
EAN: 4007841 081829
E-No: 535900069

TECHNICAL DATA

Surface	Presence detector	Electronic scalability	Yes
Mains power supply	220 – 240 V / 50 – 60 Hz	Mechanical scalability	No
With bus coupling	Yes	Radial reach	Ø 15 m (177 m ²)
Settings via	Smartphone Tablet Bluetooth Mesh App Bus	Tangential reach radius	Ø 15 m (177 m ²)
With remote control	No	Presence reach	Ø 15 m (177 m ²)
Dimensions (L x W x H)	33 x 123 x 123 mm	True Presence radial reach	Ø 9 m (64 m ²)
Sensor Technology	High frequency	Photo-cell controller	No
Transmitter power	< 10 mW	Twilight setting	2 – 2000 lx
HF-system	7,2 GHz	Twilight setting TEACH	No
Interconnection	Yes	Main light adjustable	No
Interconnection via	DALI bus Bluetooth Mesh	Basic light level function	No
Application, place	Indoors	Functions	Motions sensor Light sensor
Application, room	open-plan office hotel room classroom conference room / meeting room	Continuous light	selectable
Installation site	ceiling	Control output, Dali	Addressable/slave
Type of installation	Concealed wiring	IP rating	IP20
Mounting height	2 – 12 m	Ambient temperature	from 0 up to 50 °C
Optimum mounting height	2,8 m	Material	Plastic
Mounting height max.	12,00 m	Housing material	Plastic
Power consumption	1 W	Colour	white
With motion detector	Yes	Colour, RAL	9003
Capture	also through glass, wood and stud walls	Manufacturer's Warranty	5 years
Detection angle	360 °	IDs, certificates	DALI-2
Angle of aperture	160 °	Includes corner wall mount	No
Sneak-by guard	Yes		
Capability of masking out individual segments	No		

Multisensor True Presence DALI-2 Input Device — concealed

Multisensor



neva
lux

Multisensor True Presence DALI-2 Input Device — concealed

EAN: 4007841 081829

E-No: 535900069

ILLUSTRATIONS

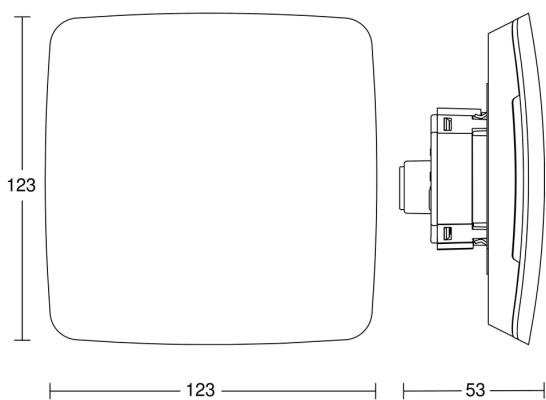

Technical drawing

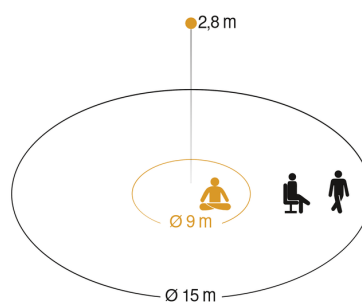

Mögliche Montagehöhe: 2,00 m – 12,00 m

Orange: True Presence

Schwarz: Bewegung und Präsenz

Field of detection

Multisensor True Presence DALI-2 Input Device — concealed

Multisensor



neva
lux

Multisensor True Presence DALI-2 Input Device — concealed

EAN: 4007841 081829

E-No: 535900069

WIRING DIAGRAMS

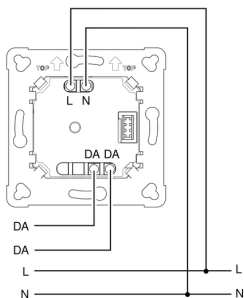

Circuit diagram

Multisensor True Presence DALI-2 Input Device — concealed

Multisensor



neva
lux

Multisensor True Presence DALI-2 Input Device — concealed

EAN: 4007841 081829

E-No: 535900069

HIGHLIGHTS



UV-resistant plastic



Interconnectable and adjustable via
Bluetooth

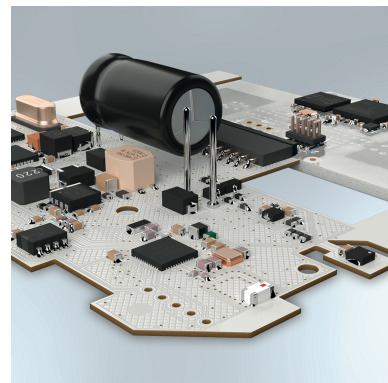

Digital high frequency sensor



Visual and auditory signal on room
climate